

# **GS3060 v3.1**

---

**GSM-GPRS INTERFACE**

# **INSTALLATION MANUAL**

---

***WARNING: This manual contains information on limitations regarding product use and function and information on the limitations as to liability of the manufacturer.***

---



# Table of Contents

<b>INTRODUCTION .....</b>	<b>1</b>
Features .....	1
Technical Specifications .....	1
Ratings .....	1
Description .....	2
<b>IDENTIFICATION OF PARTS .....</b>	<b>3</b>
<b>INSTALLING THE GS3060 .....</b>	<b>4</b>
<b>CONNECTING THE GS3060 .....</b>	<b>4</b>
<b>STATUS LEADS .....</b>	<b>5</b>
<b>OPERATING PRINCIPLES .....</b>	<b>6</b>
Simulated Land Line Mode .....	6
Panel Transmission Monitoring .....	6
GPRS Sequence .....	6
Contact ID (Voice) Mode .....	7
Inputs .....	7
Outputs .....	7
Activating the Outputs .....	7
Contact ID .....	8
Events Description .....	8
Event Codes .....	8
<b>C-24 REMOTE PROGRAMMING .....</b>	<b>8</b>
<b>GS3060 WIRING DIAGRAMS .....</b>	<b>9</b>

## FCC COMPLIANCE STATEMENT

**CAUTION: Changes or modifications not expressly approved by Digital Security Controls could void your authority to use this equipment.** This equipment generates and uses radio frequency energy and if not installed and used properly, in strict accordance with the manufacturer's instructions, may cause interference to radio and television reception. It has been type tested and found to comply with the limits for Class B device in accordance with the specifications in Subpart "B" of Part 15 of FCC Rules, which are designed to provide reasonable protection against such interference in any residential installation. However, there is no guarantee that interference will not occur in a particular installation. If this equipment does cause interference to television or radio reception, which can be determined by turning the equipment off and on, the user is encouraged to try to correct the interference by one or more of the following measures:

- Re-orient the receiving antenna
- Relocate the alarm control with respect to the receiver
- Move the alarm control away from the receiver
- Connect the alarm control into a different outlet so that alarm control and receiver are on different circuits.

If necessary, the user should consult the dealer or an experienced radio/television technician for additional suggestions. The user may find the following booklet prepared by the FCC helpful: "How to Identify and Resolve Radio/Television Interference Problems". This booklet is available from the U.S. Government Printing Office, Washington, D.C. 20402, Stock # 004-000-00345-4.

## IMPORTANT INFORMATION

This equipment complies with Part 68 of the FCC Rules. On the side of this equipment is a label that contains, among other information, the FCC registration number and ringer equivalence number (REN) for this equipment. If requested, this number must be provided to the Telephone Company.

GS3060 Product Identifier US: F53MO00BG53060

REN: 0.0B

USOC Jack: RJ-31X

## Telephone Connection Requirements

A plug and jack used to connect this equipment to the premises wiring and telephone network must comply with the applicable FCC Part 68 rules and requirements adopted by the ACTA. A compliant telephone cord and modular plug is provided with this product. It is designed to be connected to a compatible modular jack that is also compliant. See installation instructions for details.

## Ringer Equivalence Number (REN)

The REN is used to determine the number of devices that may be connected to a telephone line. Excessive RENs on a telephone line may result in the devices not ringing in response to an incoming call.

In most but not all areas, the sum of RENs should not exceed five (5.0). To be certain of the number of devices that may be connected to a line, as determined by the total RENs, contact the local Telephone Company. For products approved after July 23, 2001, the REN for this product is part of the product identifier that has the format, US: AA#EQ##TXXXX. The digits represented by ## are the REN without a decimal point (e.g., .03 is a REN of 0.3). For earlier products, the REN is separately shown on the label.

## Incidence of Harm

If this equipment GS3060 causes harm to the telephone network, the telephone company will notify you in advance that temporary discontinuance of service may be required. But if advance notice is not practical, the Telephone Company will notify the customer as soon as possible. Also, you will be advised of your right to file a complaint with the FCC if you believe it is necessary.

## Changes in Telephone Company Equipment or Facilities

The Telephone Company may make changes in its facilities, equipment, operations or procedures that could affect the operation of the equipment. If this happens the Telephone Company will provide advance notice in order for you to make necessary modifications to maintain uninterrupted service.

## Equipment Maintenance Facility

If trouble is experienced with this equipment for repair or warranty information, please contact the facility indicated below. If the equipment is causing harm to the telephone network, the Telephone Company may request that you disconnect the equipment until the problem is solved. This

equipment is of a type that is not intended to be repaired by the end user. DSC c/o APL Logistics, 757 Douglas Hill Rd., Lithia Springs, GA 30122

## Additional Information

Connection to party line service is subject to state tariffs. Contact the state public utility commission, public service commission or corporation commission for information.

Alarm dialling equipment must be able to seize the telephone line and place a call in an emergency situation. It must be able to do this even if other equipment (telephone, answering system, computer modem, etc.) already has the telephone line in use. To do so, alarm dialling equipment must be connected to a properly installed RJ-31X jack that is electrically in series with and ahead of all other equipment attached to the same telephone line. Proper installation is depicted in the figure below. If you have any questions concerning these instructions, you should consult your telephone company or a qualified installer about installing the RJ-31X jack and alarm dialling equipment for you.

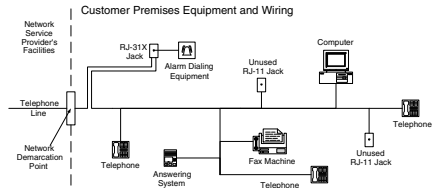

## Industry Canada Compliance Statement

This Equipment meets the applicable Industry Canada Terminal Equipment Technical Specifications. This is confirmed by the registration number. The abbreviation, IC, before the registration number signifies that registration was performed based on a Declaration of Conformity indicating that Industry Canada technical specifications were met. It does not imply that that Industry Canada approved the equipment. The Ringer Equivalence Number (REN) for this terminal equipment is 0.0. The REN assigned to each terminal equipment provides an indication of the maximum number of terminals allowed to be connected to a telephone interface. The termination on an interface may consist of any combination of devices subject only to the requirement that the sum of the Ringer Equivalence Numbers of all devices does not exceed 5.

Cet équipement est conforme aux spécifications techniques applicables aux équipements terminaux d'Industrie Canada. Ceci est confirmé par le numéro d'enregistrement. L'abréviation IC précédant le numéro d'enregistrement signifie que l'enregistrement a été effectué sur la base de la Déclaration de conformité indiquant que le produit est conforme aux spécifications techniques d'Industrie Canada. Ceci n'implique pas que le produit ait été approuvé par Industrie Canada.

Le nombre équivalent de sonneries (REN) de cet appareil terminal est 0.0. Le REN attribué à chaque équipement terminal fournit une indication sur le nombre maximum de terminaux pouvant être connectés sur une interface téléphonique. La terminaison sur une interface peut constituer en n'importe quelle combinaison d'appareils, à la condition seulement que la somme des Nombres Équivalents des sonneries de tous les appareils ne soit pas supérieure à 5.

This Class B digital apparatus meets all requirements of the Canadian interference-causing equipment regulations. Cet appareil numérique de la Classe B respecte toutes les exigences de règlement sur le matériel brouilleur du Canada.

The term "IC:" before the radio certification number only signifies that Industry Canada technical specifications were met.

**WARNING: To satisfy FCC RF exposure requirements for mobile transmitting devices, a separation distance of 20cm or more must be maintained between the antenna of this device and persons during device operation.**

# INTRODUCTION

The GS3060 is a backup wireless communicator that sends alarm system information to a System III or System II receiver through a GSM/GPRS wireless network or to a standard land-line receiver through the GSM voice channel. For use with listed compatible control units as indicated in the control unit manufacturer's installation instructions.

## Features

- Compatible with any listed panel that supports 4 or 10-digit Contact ID
- Simulates land line
- Switches automatically to GSM network in the event of land line trouble (line down)
- GSM Signal Indicator
- 4 programmable outputs
- Houses 12V - 1.2 Ah battery
- Case Tamper Output
- Land-line Overvoltage Protection
- Dual-Band GSM Radio
- 4 Programmable Inputs
- GPRS/Internet communication with Sur-Gard System III / II
- PTM Feature 4 phone numbers programmable for Contact ID Dialer
- 4 numbers programmable for Contact ID Dialer through GSM voice channels

## Technical Specifications

The input voltage to the GS3060 can be drawn from the UL/ULC Listed Control Panel or provided by an external UL Listed power supply rated for the application (external power-limited source).

**NOTE: The power supply must be Class II, Power Limited.**

## Ratings

### Power Supply Ratings

Input Voltage: ..... 9 - 14Vdc (13.8Vdc typical)

Current: ..... 120mA\* (JP3 - OFF and internal battery required) or 500mA\* (JP3 ON)

\* Plus any current drawn from the GS3060 AUX+ terminal

Battery: ..... sealed, rechargeable type, rated 12V/1.2Ah

**NOTE: Battery must be replaced every 3-5 years.**

Recharging current: ..... 50mA

### Current consumption

Standby current: ..... 120mA

Alarm (Transmitting) current: ..... 450mA

PGM outputs: ..... 4, open collector, rated 50mA

Operating frequency: ..... 850/1900MHz

Antenna Gain: ..... 2.0dBi

### Environmental specifications

Operating temperature: ..... 0°C-49°C (32°F-120°F)

Humidity: ..... 93%RH Maximum (Non-Condensing)

### Mechanical specifications

Metal enclosure, painted; dimensions: ..... 138mm x 224mm x 55mm / 5.4" x 8.8" x 2.2"

Weight (without battery): ..... 900g / 3.2oz

Internal Event Buffer (communications): ..... 256 Events (not viewable)

Maximum loop resistance of line between the device connected in series on T1/R1: ..... 1KOhm

*This equipment GS3060 is fixed and shall be installed by Service Persons only (Service Person is defined as a person having the appropriate technical training and experience necessary to be aware of hazards to which that person may be exposed in performing a task and of measures to minimize the risks to that person or other persons). It shall be installed and used within an environment that provides the pollution degree max 2, over voltages category II, in non-hazardous, indoor locations only. This manual shall be used with the Installation Manual of the alarm control panel. All instructions specified within that manual must be observed.*

## Description

---

This GS3060 manages transmissions to a central station and can simulate the land line in the event of trouble (land line down) or even substitute the land line completely in areas where the GSM service is provided and a land line is not available.

The GS3060 has the capability of communicating alarm signals via the GPRS data network. The capability enables a fast reliable path to central stations equipped with a Sur-Gard System III or System II receiver. By connecting a GS3060 to a control panel's standard PSTN interface, telephone based Contact ID signals are decoded and seamlessly routed through the GPRS network to any of the compatible receiver options. When configured accordingly, the GS3060, upon line failure, instead of using GPRS, can also connect the call on the GSM voice channels call based on the panel dialed number.

**The performance of the GS3060 depends greatly on GSM network coverage, therefore, it should not be mounted without first performing placement tests to determine the best location for reception (minimum one green LED is ON). Optional antenna kits are available.**

**The GS3060 requires enrollment with CONNECT 24 to operate. Dealer application forms and additional information on the CONNECT 24 Voice Response Unit (VRU) and web user-interface can be found at [www.connect24.com](http://www.connect24.com) or at the following telephone numbers:**

**USA 1-888-251-7458**

**CANADA 1-888-955-5583**

For UL Residential Fire and Burglary installations, the GS3060 is listed as a primary (sole) communication means or as a back-up when used in conjunction with a POTS line (dialer).

For UL Commercial Burglary installations, the GS3060 is listed for supplementary (back-up) use in conjunction with a POTS line (dialer).

The GS3060 shall be powered from any compatible listed control unit or compatible listed power supply that provides an output voltage within the range of 9-14Vdc. The power supply shall be listed for burglary applications and provide a minimum of 4h standby power capabilities. Example of suitable listed compatible control unit is DSC Model PC1864 with AUX output rated 11.1 – 12.6Vdc. Example of suitable listed Power Supply is DSC Model PC5404 with AUX output rated 11.6 – 12.6Vdc. For ULC Commercial Fire Monitoring installations the GS3060 is listed as a passive communication system when used in conjunction with a POTS line (dialer). Fire alarms shall be sent simultaneously over both communication methods (GSM network and PSTN).

For ULC Commercial Burglary installations the GS3060 is listed as a passive communication system with communication line security level P2 when used in conjunction with a POTS line (dialer).

For ULC Residential Fire and Burglary installations the GS3060 is listed as a primary (sole) communication means or as a back-up when used in conjunction with a POTS line (dialer).

**ATTENTION: The GS3060 is equipped with a current limiter that limits current demand on the 12VDC power input to 120 mA. The current limiter is enabled by default (see Part# 8 in "Identification of Parts" on page 3) with JP3 in the OFF position. The current limiter can be disabled (bypassed) with jumper JP3 in the ON position. When the GS3060 12VDC power input is supplied by the Alarm Panel Aux+ output, DSC recommends that the current limiter be active to limit the demand from the panel. If the Alarm panel is intended to supply all of the current demand, you must ensure that the panel can supply 500mA and that the current limiter is disabled. When the GS3060 transmits, the current demand exceeds 120 mA (500mA). with the current limiter in place, the additional current demand is supplied by the GS3060 battery.**

**NOTE: With the current limiter active, there is a risk of discharging the GS3060 battery when transmission frequency is high. The back-up battery must always be connected to the device when the current limiter is ON.**

If the GS3060 Power is supplied by an External Power Supply (13.8 V<sub>-</sub>, ±2%, 1A), the current limiter must be disabled to allow the full current demand to be supplied from the Power Supply. In this configuration the GS3060 battery is not required.

# IDENTIFICATION OF PARTS

The numbers in square brackets [ ] in this manual refer to the main parts of the GS3060 (see Fig. 1 below) described in this section.

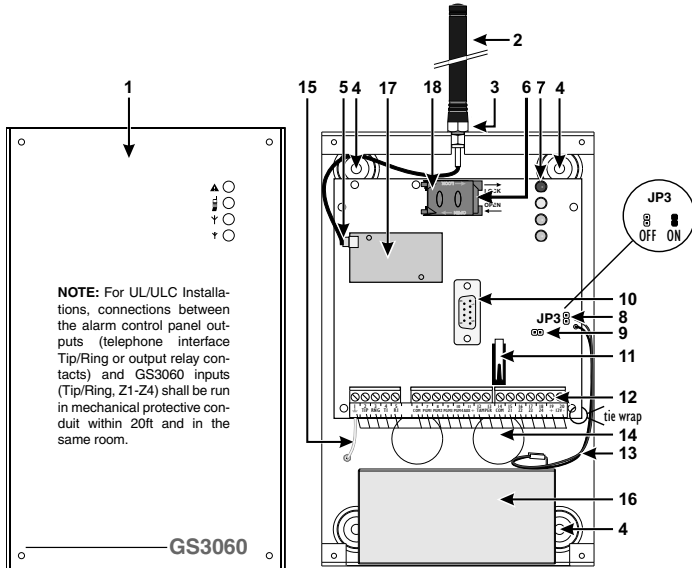

All circuits are classified for UL installations as Power Limited/Class II Power Limited except for the battery leads which are not power limited. Do not route any wiring over circuit boards. Maintain at least 1" (25.4mm) separation. A minimum 1/4" (6.4mm) separation must be maintained at all points between Power Limited wiring and all other Non-Power Limited wiring. Route wires as indicated in the diagram.

PARTS	
1	Metal Casing
2	GSM Antenna
3	GSM Antenna Mounting Hardware
4	Anchor Screw Holes (3mm)
5	Connector for GSM Antenna
6	SIM Card
7	Status LEDs (see page 5)
8	JP3 Current Limitation Jumper (refer to ratings section)
9	Programming Jumper (Do not short these pins)
10	RS-232 Connector
11	Tamper Switch
12	Terminal Blocks
13	Battery Leads
14	Cable Entry
15	Earth Ground Wire
16	12V-1.2Ah Battery
17	GSM Radio Module
18	SIM Card Holder

Figure 1 - Parts

## INSTALLING THE GS3060

### **CONNECT 24 Enrollment Information**

Only authorized dealers can enroll a GS3060 with CONNECT 24. Dealer application forms and additional information on the CONNECT 24 Voice Response Unit can be found at the CONNECT 24 web site [www.connect24.com](http://www.connect24.com). Please contact CONNECT 24 at the number below for assistance:

USA 1-888-251-7458

CANADA 1-888-955-5583

**NOTE: Steps 1 and 2 should be completed before powering the GS3060 unit.**

### **STEP 1 - Activate Your SIM Card**

Your SIM card must be activated with Connect 24 prior to use. **Please call the Voice Response Unit (VRU) at least 24 hours prior to installation at 1-866-910-3865.**

### **STEP 2 - Initialize the GS3060 with Connect 24**

Call the VRU at the toll-free number. Follow the voice prompts and enter in your profile number, installer ID number, installer PIN number and central station number. Ensure all information is available before calling the VRU. All this information can be found in your VRU Enrollment Package.

### **STEP 3 - Determine Best Signal Location**

1. Remove the screw and the front cover [1].
2. Fit the antenna [2] (ensure that the bolt [3] is fastened tightly).
3. Using the connector [5], connect the GSM Module [17]. Ensure the connector is secure.

**NOTE: Before inserting or removing the SIM card, please ensure the unit is powered down.**

4. Power up the GS3060 and check signal strength.
  - Connect battery to the RED and BLK battery leads.
  - Connect DC Power source to +/- 12V terminals.
  - Allow unit to power up
  - The green LEDs will indicate the signal strength. The bottom green LED must be ON for the location to be acceptable. Please refer to the "Status LEDs" section for more information.
5. Power down the GS3060 by removing the DC power source and battery leads.

### **STEP 4 - Connect the GS3060**

1. Using the cabinet, mark the 4 screw locations then drill the anchor screw holes.

**NOTE: Check for cable conduits and water pipes before drilling.**

2. Using anchor screws (not included), mount the cabinet to the wall.
3. Run the cables, then pull them through the cable entry [14] or the knockouts provided.
4. Complete the connections on the terminal board [12]. **Ensure power and Telco circuit connections are made only after the cabinet has been secured to the building or structure and has been connected to the protective earth ground.** Descriptions of the terminals can be found in the "Connecting the GS3060" section.
5. Using the 4 screws, reattach the front cover [1] securely to the cabinet.

**NOTE: Please refer to Figure 2 at the end of this manual for wiring diagram.**

## CONNECTING THE GS3060

### **⏏ (1) Earth Ground**

This terminal must be connected to the Mains Earth, in order to comply with the Telecommunications Network Safety Standards (Overvoltage Protection Requirements).

### **TIP (2) / RNG (3) External telephone line**

These terminals must be connected directly to the incoming telephone line .

### **T1 (4) / R1 (5) Internal telephone line**

These terminals must be connected to the TIP and RING of the control panel.

### **COM(6,14) Common**

This terminal is connected internally to Power Ground.



## PGM1 (7), PGM2 (8), PGM3 (9), PGM4 (10) Programmable open-collector outputs

These outputs can be activated by programmed events, refer to "Activating the Outputs" for details. The maximum current sink of each output must not exceed 50mA.

## AUX+ (11) Auxiliary 12V Output

+12V Output, 200mA PTC Protected. **NOTE: Current drawn from this terminal is directly from the power supply. This needs to be added to the GS3060 current when determining the total draw on the host panel or power supply. Jumper JP3 does not limit the current available on this output.**

## Tamper (12-13)

These terminals are connected in series to the Tamper microswitch [11]. They will be closed when the cabinet is properly closed, and will open when the front cover is removed.

## Z1-Z4 (15-16-17-18) Programmable Inputs

These terminals can be set up to trigger events. Refer to "Inputs" section for details.

## 12V (19), COM (20) Device Power Supply

These terminals must be connected to a rated power supply. Once the connections are completed, connect the Red and Black wires [13] to a 12V, 1.2Ah battery.

## Jumper JP3

**JP3 ON** - Full power comes from the host panel or external power supply. Supply must be capable of up to 700mA, the GS3060 battery must NOT be connected.

**JP3 OFF - Current Limiting Mode.** Host panel or external supply provides standby current. Supply must be capable of 120mA plus any current drawn from AUX+ terminal. GS3060 battery must be installed for proper operation. The Power Supply must have a minimum voltage of 13.5 to ensure sufficient battery charge.

**NOTE: This mode of operation must not be used for ULC Listed Fire Monitoring Installations.**

**NOTE: When disposing of batteries, follow the instructions and and precautions printed on the batteries, and contact your municipal offices for information on the disposal of used batteries.**

# STATUS LEDS

The GS3060 interface has 4 status LEDs. The following describes the Control panel status LEDs.

**NOTE: The top two LEDs will blink during the Initializing and Programming phases.**

**▲ RED** — This LED is Normally OFF, it will blink in the event of trouble. This LED will switch ON within 3 minutes in the event of GSM Module [17] trouble, or when the GSM Network is unavailable (NO SERVICE). If this LED blinks, the following list will indicate the specific trouble based on the number of blinks, by priority. On power-up, the GS3060 will check for trouble conditions to be restored in the order listed below. It will indicate the status of the highest priority, unrestored trouble condition with the corresponding number of flashes of the RED LED. Once the highest priority trouble condition has been cleared, the next highest priority trouble condition will be displayed.

**1 flash** - Battery Trouble (*Battery absent or battery with low voltage output*)

**2 flashes** - Radio/SIM Failure (*Battery absent or check SIM Card connection*)

**3 flashes** - GSM Network Problem (*SIM not active, poor signal strength, antenna not connected*)

**4 flashes** - Insufficient Signal Strength (*Poor location*)

**5 flashes** - Connect 24 Configuration SMS Failure (*Improper VRU programming. Once the configuration is ready, remove power for 2-3 seconds to allow the unit to restart and request again.*)

**6 flashes** - Receiver Not Available (*Improper VRU programming, receiver absent*)

**7 flashes** - Power Supply Trouble (*DC power supply absent*)

**Off** - No Troubles

**📞 YELLOW** — This LED will switch ON when the interface switches to the GSM Network (due to land line trouble). This LED will blink slowly in the event of an incoming or outgoing voice call (regardless of the operating status of the land line). This LED can also blink quickly once (GPRS TX) or twice (GPRS RX).

**↕ GREEN (Top)** — When this LED is ON, the reception is optimal. This LED will switch ON only when the other GREEN LED is ON.

**↕ GREEN (Bottom)** — If this LED is OFF and the RED LED is ON, the GSM Network service is unavailable (NO SERVICE). This LED will Blink when the GSM Network reception is bad. If this LED is ON, the GS3060 will be able to communicate to the GSM network.

# OPERATING PRINCIPLES

## Simulated Land Line Mode

The simulated land line provides the alarm control panel (with dialer interface) with a backup line in the event of PSTN line trouble. If the voltage on the land line terminals (**TIP/RNG**) drops below 4V for a period of between 10 to 45 seconds (depending on the device connected to the **T1/R1** terminals), the GS3060 will switch the connected telephone device to the GSM Network for approximately 30 to 40 seconds. At the end of this interval, it will check the land line:

- if the land line has been restored, it will switch the connected device back to the land line;
- if the land line is still down, it will continue to simulate the land line until it is restored. The GS3060 will not switch during ongoing calls

**NOTE: When the land line is down, the GS3060 will provide a dial tone to any device connected to T1 and R1, including any telephones on the premises. However, the premise phones will not be able to dial out over the GS3060.**

## PTM (Panel Transmission Monitoring)

The GS3060 can also monitor the panel's attempt to communicate with the central station. If it determines the panel is having difficulty it will switch the line to the GSM network. This feature is only active when the GS3060 is configured as a backup communicator. This feature is in addition to the regular line voltage detection.

The GS3060 will monitor the phone line for four consecutive failed attempts within a 12-minute window. A failed attempt is considered when line seizure occurs with dialing (alarm panel or customer telephone), but no 1400Hz tone (or Contact Kiss-off) is detected from the receiver.

Once this condition is met the GS3060 will connect the panel to the GSM network to communicate the events. Once the GS3060 switches the line it will stay in this mode until the panel hangs up. On the next event the GS3060 will restart the error detection sequence before switching.

The GS3060 will perform this sequence on any phone number that is detected on the line. Specific central station phone numbers can be programmed into the GS3060 if desired. Up to four, 20-digit numbers can be added to your installer profile at Connect 24. If programmed, the GS3060 will only look for Contact ID kiss-off after these numbers are dialed. A TLM trouble (PGM output activation and/or reporting code if applicable) will also be activated and/or transmitted when the PTM is activated. The restoral will be sent at the end of the call.

## GPRS Sequence

- When alarm is triggered, the Control Panel goes off-hook
- The GS3060 will assert dial tone
- Control Panel dials the number of the central station. Ensure the alarm panel inserts a minimum 1-second pause, or has dial tone search enabled before dialing the number
- The GS3060 detects the DTMF dialing and stops dial tone

**NOTE: The GS3060 is unable to decode pulse dialing.**

- The GS3060 will send the required Contact ID dual tone handshake to the panel
- After receiving the handshake, panel transmits alarm message in Contact ID format
- The GS3060 decodes and transforms Contact ID digits into the IP packet and sends it to the Central Station Receiver over the GPRS network
- The receiver acknowledges the alarm and sends command to the GS3060 to generate the corresponding 1400Hz kiss-off signal for 800ms minimum
- After the GS3060 generates kiss-off, the panel goes on-hook if no more alarms need to be sent, or it can send the next alarm

## Contact ID (Voice) Mode

---

This operating mode allows the GS3060 to send calls to the Central Station through the GSM voice channel. When active, the GS3060 will transfer the phone number dialed by the panel to the GSM network and connect with the land line receiver through the GSM voice channel.

The Z1 - Z4 alarms and other event codes can be generated in Contact ID format and transmitted to a standard PSTN line card. Event Codes and Customer Account Codes must be programmed to transmit event signals.

The GS3060 will call all programmed telephone numbers for each event (four telephone numbers maximum of up to 20 digits (digits and + signs). The GS3060 will make three attempts for each telephone number then quit if unsuccessful. If programmed, the PTM numbers will also be used as filters. Voice calls are restricted to the phone numbers in the PTM table.

**NOTE: The GS3060 default on-line time limit is 3 minutes.**

**NOTE: The GS3060 has been verified against major manufacturers for CONTACT ID, 10 bps and 20 bps protocols and, in places with optimum GSM signal reception, SIA format. However, since the GS3060 unit is only acting as a bridge, good performance will be determined by the alarm panel connected to the GS3060. Communication tests must be performed.**

## Inputs

---

The GS3060 has 4 inputs that can be used to trigger specific communications. These events will transmit using Contact ID format with Inputs 1-4 reporting as [991] to [994] respectively. Default settings are:

INPUT 1 - FIRE

INPUT 3 - BURGLARY

INPUT 2 - PANIC ALARM

INPUT 4 - SYSTEM TROUBLE

These inputs are normally open and will activate when a short condition is detected between the terminal and the COM. Refer to the GS3060 Wiring Diagram (Figure 2) at the back of this manual.

**NOTE: These inputs communicate using Contact ID format.**

**NOTE: For UL/ULC installations, connections between alarm panel outputs and GS3060 inputs shall be run in mechanical protective conduits. To reduce interference with the antenna, it is recommended that the metal conduit is not connected to the knock-outs on the top of the cabinet.**

## Outputs

---

The GS3060 has 4 programmable outputs to activate in response to the associated events. Refer to the GS3060 Wiring Diagram (Figure 2) at the back of this manual.

### Activating the Outputs

---

The GS3060 has 4 open collector outputs capable of a maximum of 50mA. Internal events on the GS3060 can trigger the outputs to turn on an LED or activate an input on the host panel. The default settings are as follows:

#### OUTPUT 1 - Land Line Trouble

Output is normally high and will switch to ground when the telephone line is down.

#### OUTPUT 2 - GSM Model or Network Trouble

Output is normally high and will switch to ground when the GS3060 can't connect or communicate to the GSM network.

#### OUTPUT 3 - Power Supply or Battery Trouble

Output is normally high and will switch to ground when there is a problem with the power source.

#### OUTPUT 4 - General Module Trouble

Output is normally low and will switch to high when a GSM Trouble, Power Supply/Battery Trouble and/or a Failure to Communicate (FTC) trouble is detected.

**NOTE: Once an output has been activated automatically, it will not restore its state until all the causes of activation are cleared.**

## Contact ID

---

### Events Description

#### Event Codes

INPUT 1 ACTIVATION: .....	E110 FIRE ZONE 001 991
INPUT 1 RESTORAL: .....	R110 FIRE ZONE 001 991
INPUT 2 ACTIVATION: .....	E120 PANIC ALARM ZONE 002 992
INPUT 2 RESTORAL: .....	R120 PANIC ALARM ZONE 002 992
INPUT 3 ACTIVATION: .....	E130 BURGLARY ZONE 003 993
INPUT 3 RESTORAL: .....	R130 BURGLARY ZONE 003 993
INPUT 4 ACTIVATION: .....	E300 SYSTEM TROUBLE ZONE 004 994
INPUT 4 RESTORAL: .....	R300 SYSTEM TROUBLE ZONE 004 994
PSTN LINE DOWN: .....	E351 TELCO 1 FAULT 000
PSTN LINE RESTORAL: .....	R351 TELCO 1 FAULT 000
12V INPUT LOSS: .....	E337 EXP. MOD. DC LOSS 000
12V INPUT RESTORAL: .....	R337 EXP. MOD. DC LOSS 000
LOW BATTERY ALERT: .....	E338 EXP. MOD. LOW BAT 000
LOW BATTERY RESTORAL: .....	R338 EXP. MOD. LOW BAT 000
PERIODIC REPORT: .....	E603 PERIODIC RF XMISSION 000
PERIODIC REPORT (WITH OFF-NORMAL CONDITION) .....	E608 PERIODIC TEST XMISSION SYSTEM TROUBLE PRESENT 000
GSM UNIT ACTIVATION: .....	R552 RADIO XMITTER DISABLED 000
GSM INTERNAL BUFFER FULL: .....	E624 EVENT LOG OVERFLOW 000
FTC RESTORAL: .....	R354 FAILURE TO COMMUNICATE 000

## "C-24 REMOTE" PROGRAMMING

The inputs, outputs and other features can be remotely programmed through Connect-24 (C-24) for fast and convenient installation through the world wide web.

**NOTE: This programming option has not been investigated by UL.**

# GS3060 WIRING DIAGRAMS

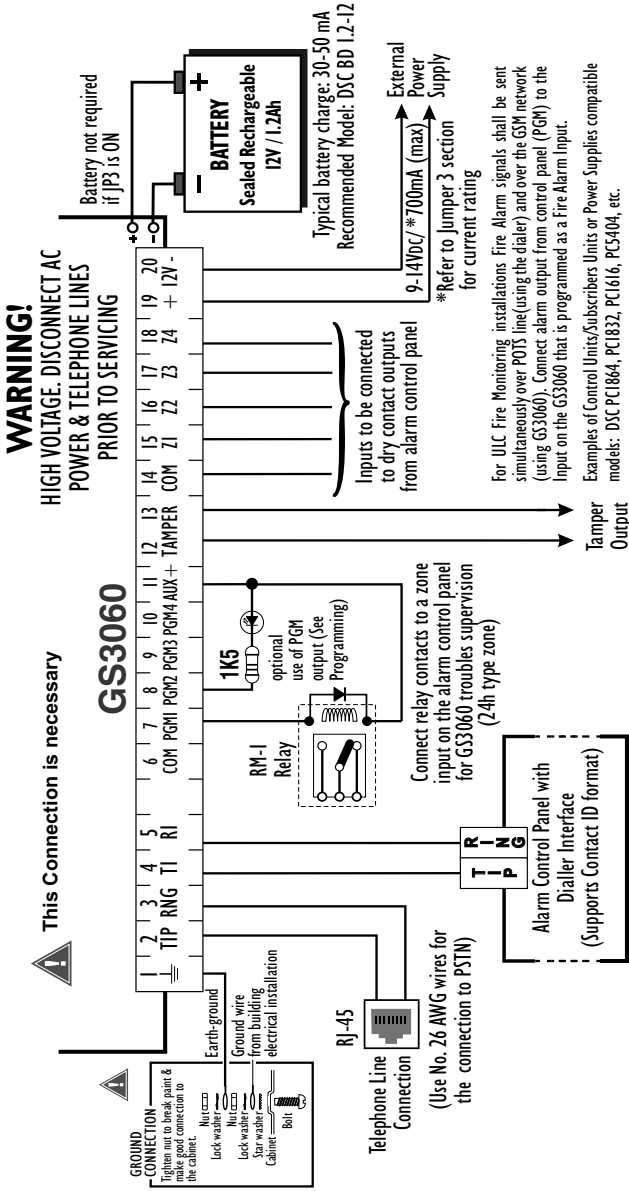

**WARNING:** Incorrect connections may result in PTC failure or improper operation. Inspect wiring and ensure connections are correct before applying power. All circuits are classified for UL installations as Power Limited/Class II Power Limited except for the battery leads which are not power limited. Do not route any wiring over circuit boards. Maintain at least 1" (25.4mm) separation. A minimum 1/4" (6.4mm) separation must be maintained at all points between Power Limited wiring and all other Non-Power Limited wiring. Route wires as indicated in the diagram.

Fig. 2 - Wiring Diagram

# GS3060 WIRING DIAGRAMS

- NOTES:**
1. Program the Control Panel's input Zone/Point as 24th "Supervisory" type with the keypad only annunciation when activated.
  2. A supervision relay, DSC model RM-2 can be used, as indicated in Fig. 4 in order to provide supervision of the control panel (for total power loss) when the GS3060 is powered by a Separate Power Supply.  
When the GS3060 is powered by the control panel the relay is not required since a loss of voltage at the power input terminals on the GS3060 will generate a trouble signal transmission to the monitoring station.
  3. Output 4 on the GS3060 must be set as "Active High".

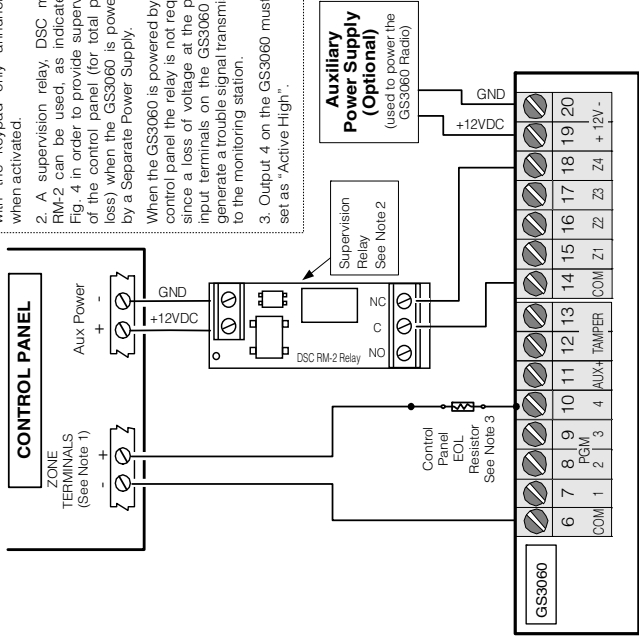

Fig. 4 - Optional Power Supply And Supervision Wiring Diagram

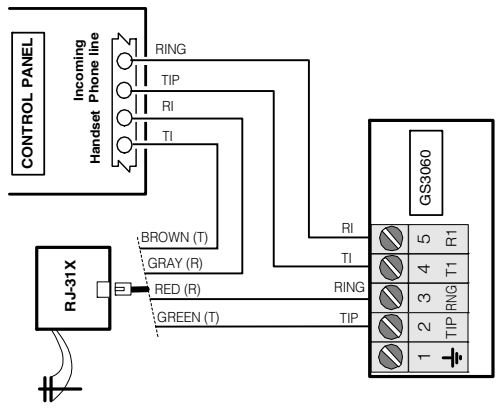

Fig. 3 - Telephone Connection



